

Gear Type Automatic Tapping Machine

HT2-316立式齒輪式自動攻牙機

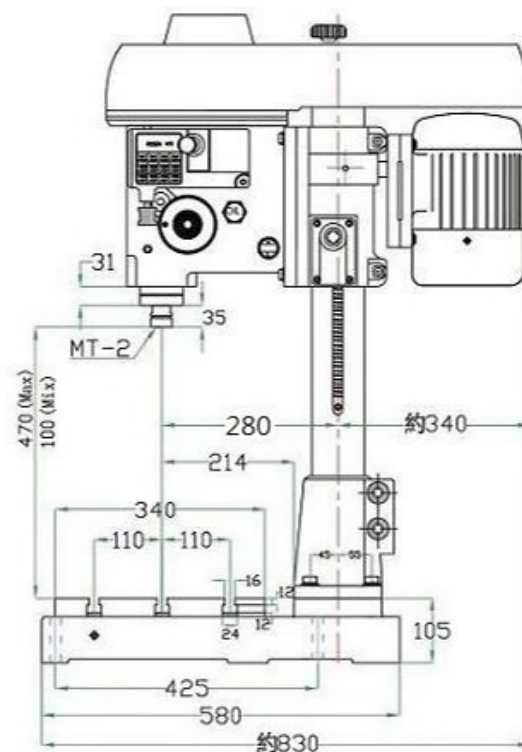
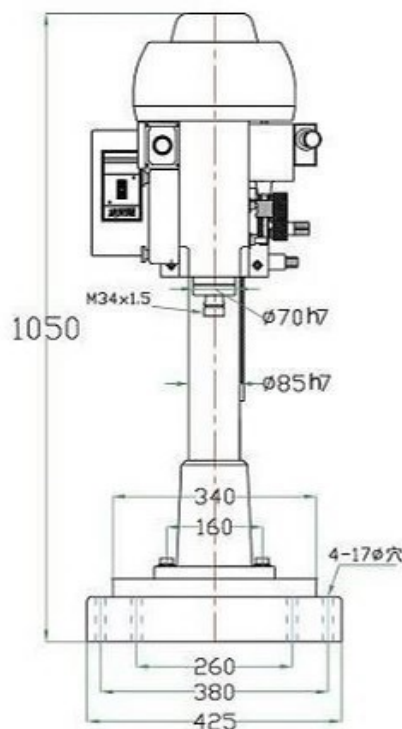

* 規格表 Specification

機種/重量	行程	旋徑	能力	主軸端和	工作台	馬達	主軸迴轉數	本機器使用齒輪螺距	多軸最大能力
Model/Weight(Kg)	Stroke	Swing	Capacity	台面距離	尺寸	Motor	Speed	Machine uses the gear pitch	m/m標準
	(mm)	(mm)	(mm)	Spindle to table	Table size(LxW)		50Hz 60Hz	每英吋的牙數	Max. number of spindles
								Number of teeth per inch	of the multiple spindle head
HT2-316	65	430	φ 5- φ 16	470	340	3相	505 620	28 24 20 19 18	M 6x 9軸
200KG					x	6P	285 340	16 14 12 11 10	M 8x 4軸
					340	1HP	155 190		M 12x 2軸