

Horizontal Gear Type Automatic Tapping Machine

HT2-317臥式齒輪式自動攻牙機

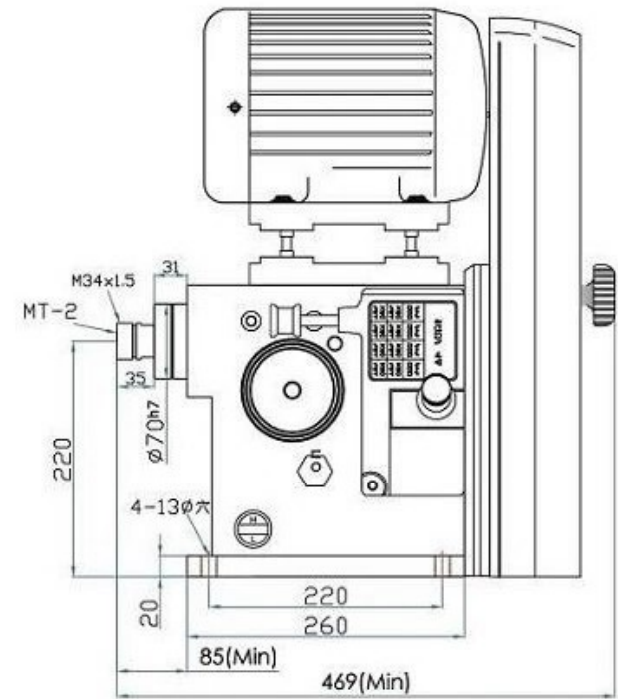
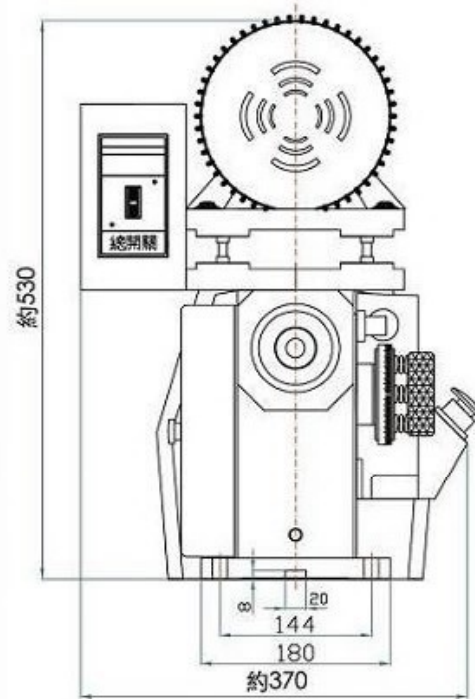

* 規格表 Specification

機種/重量	行程	旋徑	能力	主軸端和	工作台	馬達	主軸迴轉數		本機器使用齒輪螺距		多軸最大能力
Model/Weight(Kg)	Stroke	Swing	Capacity	台面距離	尺寸	Motor	Speed		Machine uses the gear pitch		m/m標準
	(mm)	(mm)	(mm)	Spindle to table	Table size(LxW)		50Hz	60Hz	每英吋的牙數		Max. number of spindles
									Number of teeth per inch		of the multiple spindle head
HT2-317	65	430	φ 5- φ 16	470	340	3相	505	620	28 24 20 19 18	0.7 0.8 0.9 1.0 1.25	M 6x 9軸
103KG					x	6P	285	340	16 14 12 11 10	1.5 1.75 2.0 2.5	M 8x 4軸
					340	1HP	155	190			M12x 2軸